

**LABORATORY TEST II**  
**GEOL 110**  
**Spring, 2008**

NAME \_\_\_\_\_ (print)

**I have neither given nor received aid on this examination.**

(signature) \_\_\_\_\_

The diagram below is your tool to help you locate places on the topographic maps used for this test. For example, if the question reads “locate the spring near the town of Grottoes (7)”, you would look in the lower left hand corner of the map, designated as section (7) on the location diagram below. Good luck!!!

Dr. E

1	2	3
4	5	6
7	8	9

### **Seneca Quadrangle (20%)**

1. What direction is Muddy Branch flowing where it is crossed by Turkeyfoot Road? (3)
2. What is the magnetic declination of this map?
3. What is the latitude and longitude of Herndon Junction (7)?
4. What do the following colors on the map represent?
  - Green
  - Blue
  - Brown
  - Black
5. Compute the gradient of Nicholas Run from the point where the 300' contour line crosses the Run, to the pond at the Northern Virginia Regional Park. (8).

6. What is the scale of this map in

a) in fractional form?

b) in inches to feet?

7. What is the contour interval of this map?

8. What is the straight-line distance (in feet) between Poplar Grove Church and Quince Orchard crossroads? (3)

9. What direction does the Potomac River flow at the middle of the map? What evidence could be used to determine this?

**Rock Deformation (15%)**

Complete the missing portions of the block diagrams below. Matching letters on beds indicate same rock layers.

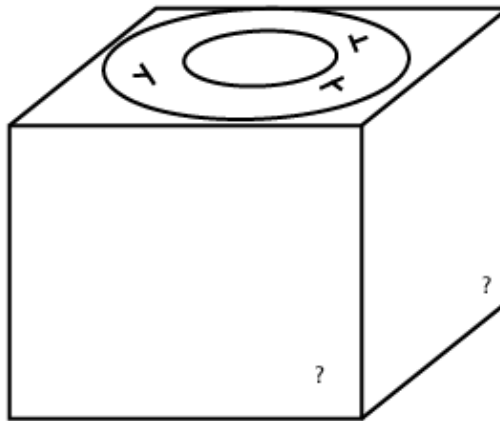
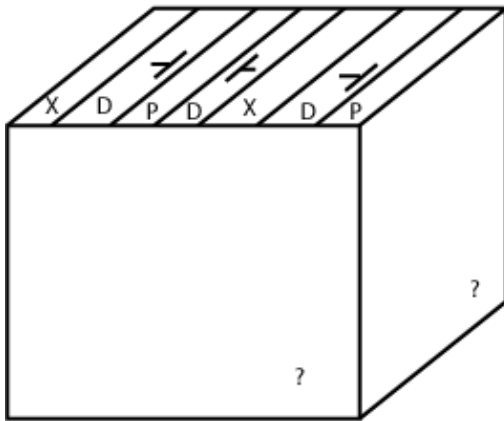
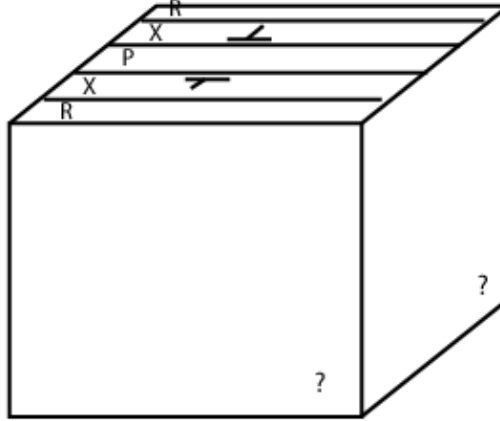
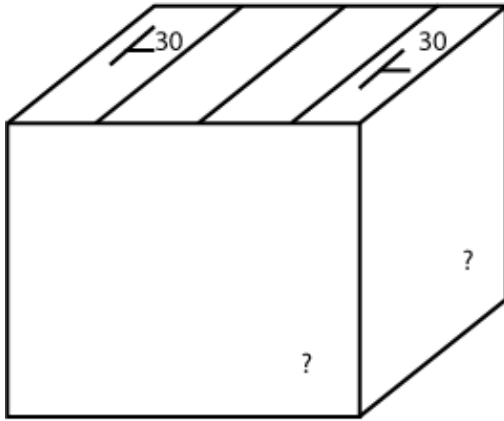

In the diagram below, for each fault, 1) name the fault (normal or reverse), and 2) give its age (younger, middle, oldest).

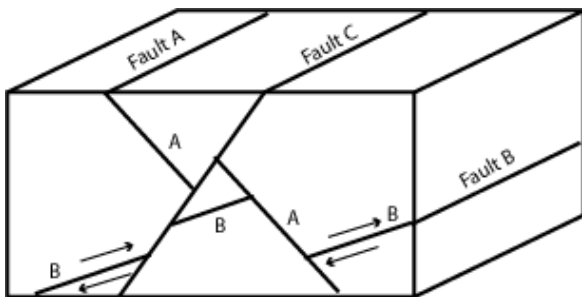

	Name of Fault	Age of Fault
Fault A		
Fault B		
Fault C		

### Geologic Cross Sections (10%)

Complete the geologic cross section below from A to A'. The map below shows a 'bird's eye' view of the surface of the earth.

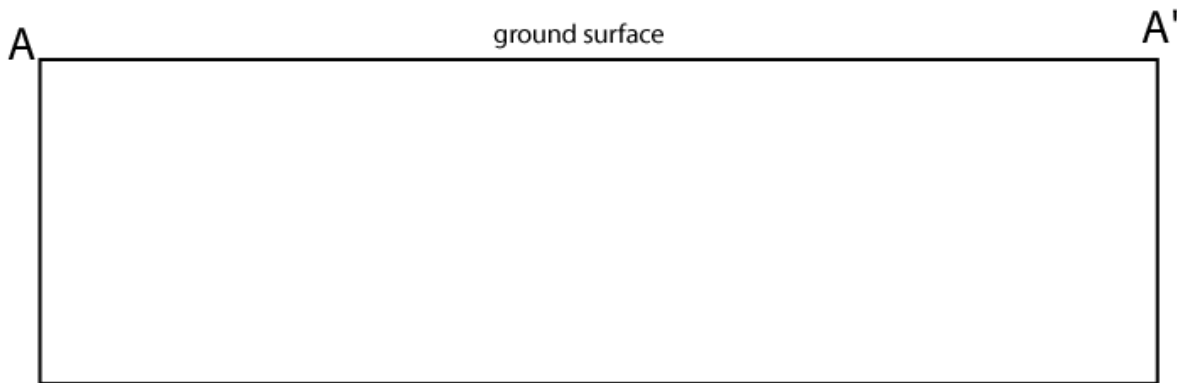
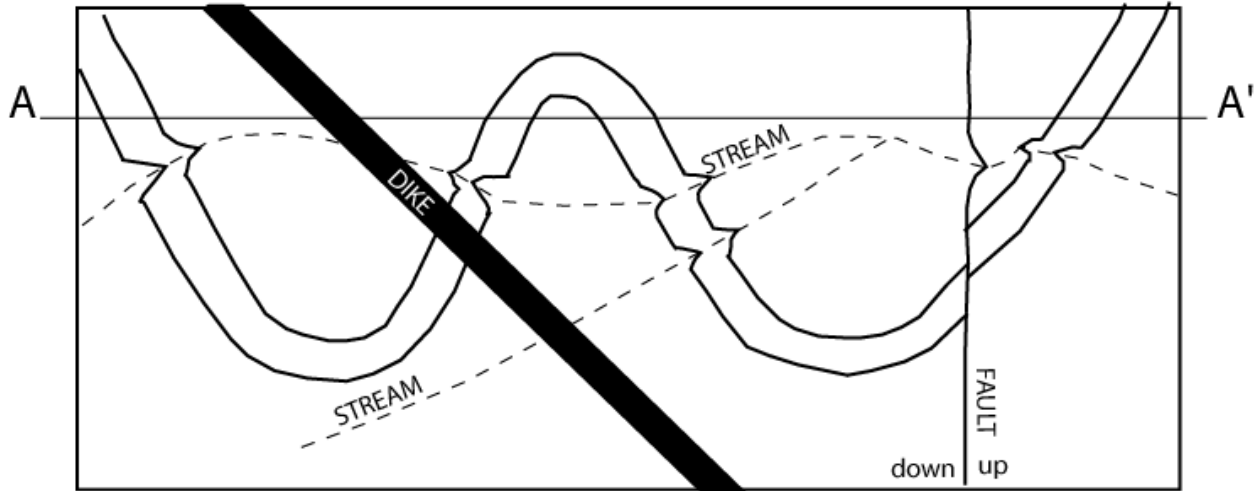

### Topographic Cross Section (10%)

Label the contours and construct a profile of the land surface along the line from A to A'. Neatness and precision are important attributes to ensure full credit.

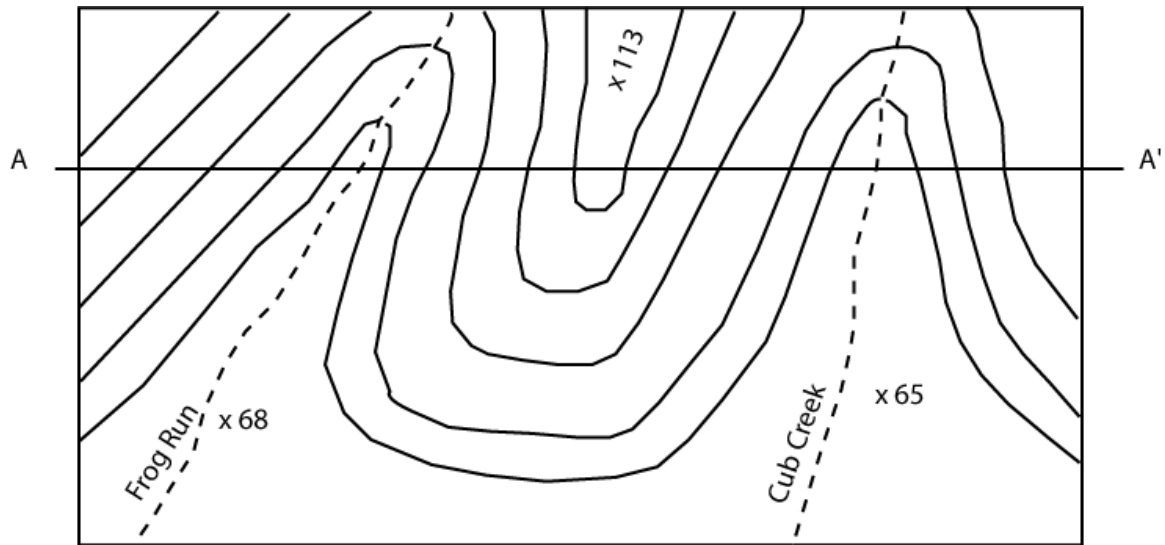





### Geologic History (10%)

List the sequence of geologic events from oldest to youngest. You do not have to give your reason or justification, such as 'Law of Superposition'.

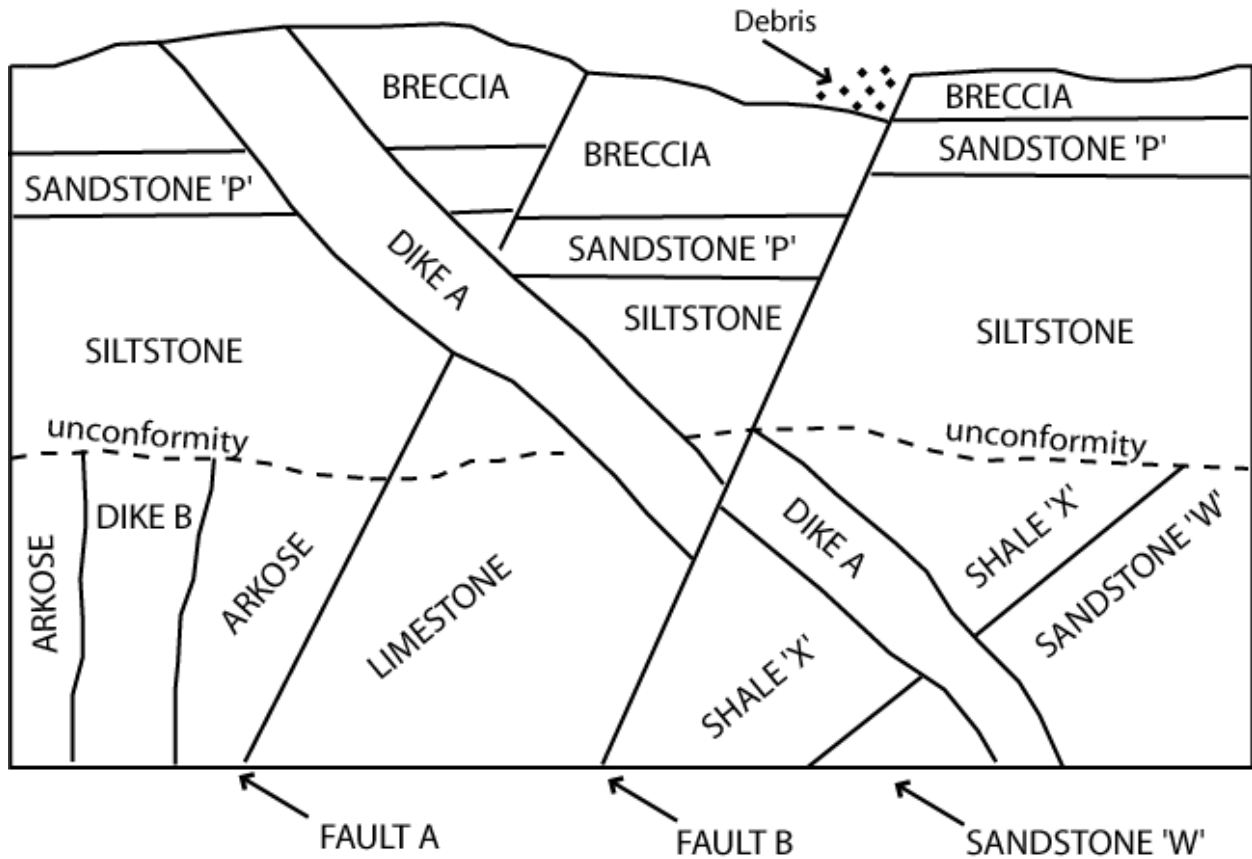

### Landform Identification (15%)

**Name the following numbered features on the diagram displayed on the chalk board.**

**1.**

**2.**

**3.**

**4.**

**5. At point 5, what is the direction of the longshore current?**

**6.**

**7.**

**8.**

**9.**

**10.**

**11.**

**12.**

**13.**

**14.**

**15.**